

## PRS-200/R410



ROOFTOP 70 KW

---

|                        |                        |         |                    |
|------------------------|------------------------|---------|--------------------|
| Nominal ton            |                        | (Ton)   | <b>20</b>          |
| Model                  |                        |         | PRS-200HWN1-R      |
| Power Supply           |                        | V,Ph,Hz | 380~415V,3Ph,50Hz  |
| Cooling                | Cooling Capacity       | Btu/h   | 240000             |
|                        |                        | kW      | 70.0               |
|                        | Power Input            | kW      | 22.6               |
| Heating                | Heating Capacity       | Btu/h   | 260000             |
|                        |                        | kW      | 75                 |
|                        | Power Input            | kW      | 23.6               |
| Max. input consumption |                        | kW      | 32.5               |
| Max. current           |                        | A       | 63.2               |
| Performance            | Indoor fan air flow    | CFM     | 8800               |
|                        | ESP                    | Pa      | 120                |
|                        | EER                    | Btu/h/W | 10.6               |
|                        | COP                    | Btu/h/W | 11                 |
| Indoor Coil            | Number of rows         |         | 4                  |
|                        | Fin spacing            | mm      | 1.3                |
|                        |                        | FPI     | 20                 |
|                        | Tube diameter          | mm      | 7                  |
| inch                   |                        | 9/32    |                    |
| Indoor fan             | Type                   |         | FC Centrifugal     |
|                        | Quantity               |         | 1                  |
|                        | Drive type             |         | Belt               |
|                        | Motors quantity        |         | 1                  |
|                        | Motor model            |         | YE2-132S-4-5.5KW   |
| Compressor             | Type                   |         | Scroll             |
|                        | Quantity               |         | 2                  |
|                        | Model                  |         | ZP144KCE-TFD-522×2 |
|                        | Brand                  |         | Copeland           |
|                        | Capacity               | Btu/h   | 120500×2           |
|                        | Refrigerant oil charge | ml      | 3253x2             |
| Outdoor Coil           | Number of rows         |         | 3                  |
|                        | Fin spacing            | mm      | 1.5                |
|                        |                        | FPI     | 17                 |
|                        | Tube diameter          | mm      | 7                  |
| inch                   |                        | 9/32    |                    |
| Outdoor Fan            | Type                   |         | Propeller          |
|                        | Quantity               |         | 2                  |
|                        | Drive type             |         | Direct             |
|                        | Motors quantity        |         | 2                  |
|                        | Motor model            |         | YS1100-6-3         |
| Refrigerant            | Type                   |         | R410A              |
|                        | Refrigerant volume     | kg      | 6.7+6.7            |
|                        | Refrigerant Control    |         | Piston             |
| Net Weight             |                        | kg      | 690                |
| Gross Weight           |                        | kg      | 720                |
| Net Dimension          | WxHxD                  | mm      | 2192x1247x1670     |
| Packing                | WxHxD                  | mm      | 2212x1284x1695     |
| Shipping               | Qty/Per 20'/40'/40'HQ  |         | 3/7/14             |
| Ambient temperature    | Cooling                |         | 10°C ~ 46°C        |
|                        | Heating                |         | -9°C ~ 24°C        |

**PRS-200HWN1-R: (Unit: mm)**

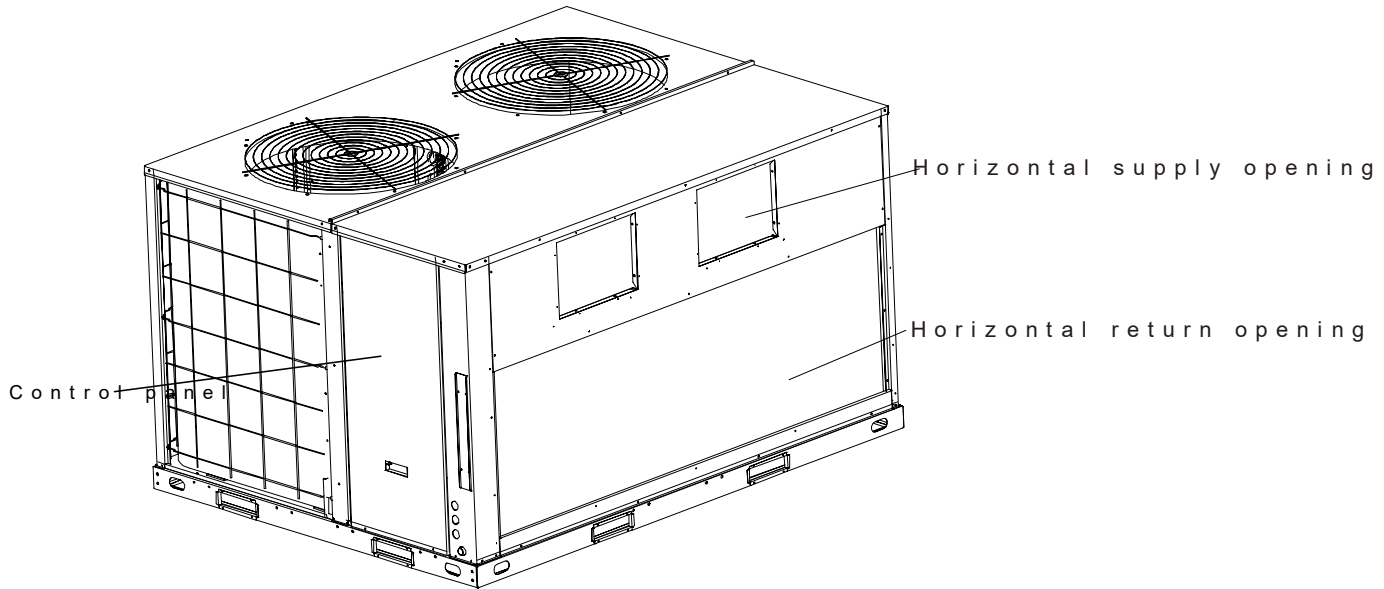
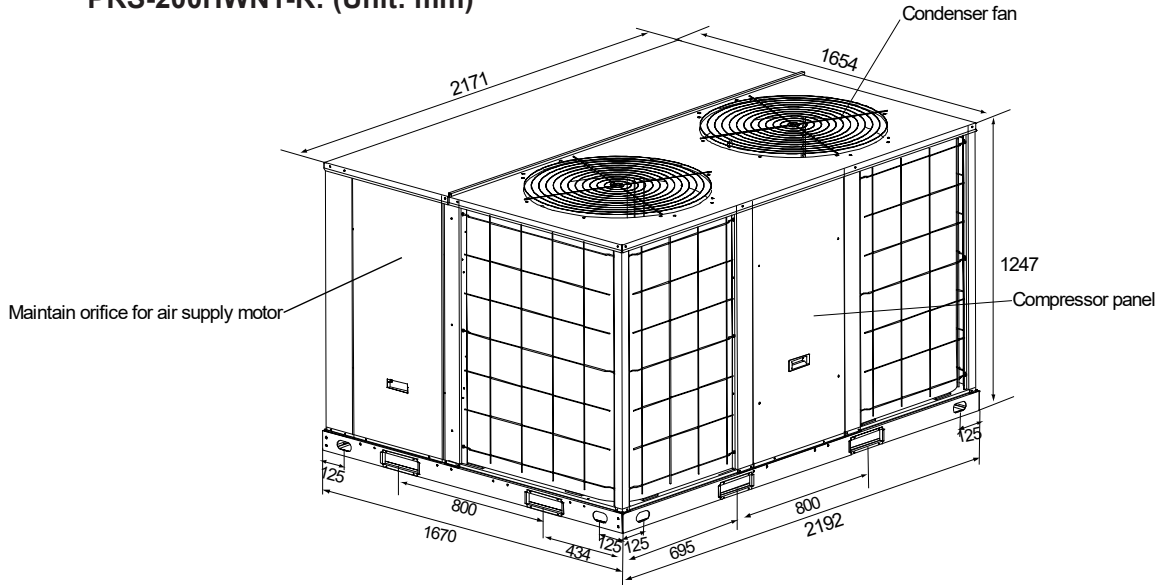

Hole for bottom installation  
14-15x20

